



ROTOBEC™
TOUGH HANDLING EQUIPMENT

HEAVY-DUTY ROTATORS

by ROTOBEC

Why **ROTOBEC** is the **BEST CHOICE**:

- 1 Heavy-Duty construction.
- 2 Simple and cost effective maintenance.
- 3 Outstanding resistance to side loading.
- 4 More than 35 years of expertise in manufacturing of heavy-duty continuous rotators and related attachments.
- 5 Every rotator is factory tested.
- 6 Trusted in more than 20 countries.



STURDY ROTATOR HOUSING
◆ High strength steel casting



Saw ready rotator

SEVERE-DUTY SWIVEL BEARINGS

SEALED AND WATERPROOF ROTATOR
◆ Protects internal components
◆ Extended greasing intervals
◆ Submersible rotator

OPERATES IN HARSH ENVIRONMENTS
-40°C   +40°C

ROTOmax™ system

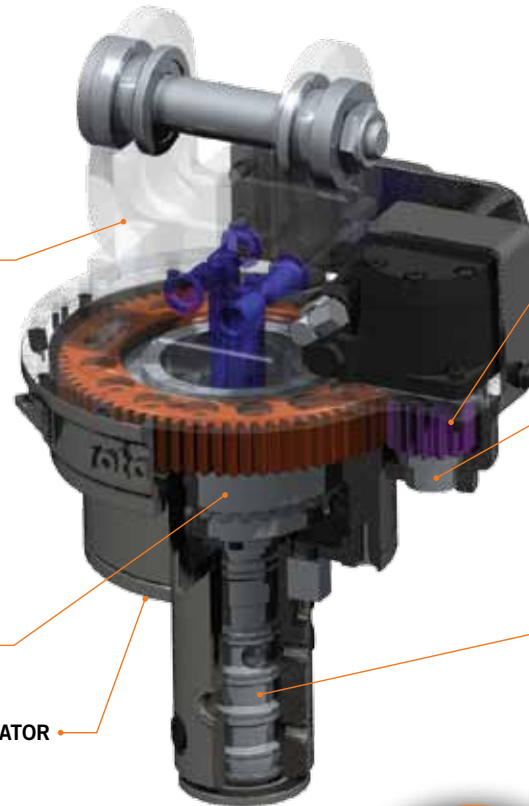

SUPERIOR INDIRECT DRIVE DESIGN

- ◆ Accepts severe side loading
- ◆ Greater swing torque
- ◆ Manufactured with tempered and hardened gears

PINION GEAR SUPPORTED BY BEARINGS ON BOTH BOTTOM AND TOP OF SHAFT

- ◆ Keeps motor shaft perfectly straight
- ◆ Leak-free rotator
- ◆ Greater gears and motor durability

FLOATING HYDRAULIC COLLECTOR

- ◆ Isolated from side loading
- ◆ No seizing and no leaking
- ◆ Precise machining



Harvesting head continuous rotation available



HEAVY-DUTY ROTATORS

by ROTOBEC

Rotomax™ system

- ◆ HEAVY-DUTY CONSTRUCTION
- ◆ SIMPLE AND COST EFFECTIVE MAINTENANCE
- ◆ OUTSTANDING RESISTANCE TO SIDE LOADING



Available for electromagnet

ROTATORS – TECHNICAL SPECIFICATIONS

MODEL	RT-142	RT-222	RT-252	RT-322	RT-502HT	RT-1002HT
Rotation	Unlimited	Unlimited	Unlimited	Unlimited	Unlimited	Unlimited
Max. excavator size	10	16	20	25	32	40
Max. axial load (dynamic)	6360	9980	11340	14514	22680	45360
Max. swing torque	956	1209	1825	1825	2628	3154
Weight	84	102	122	141	181	297

DISTRIBUTED / SERVICED BY:



Resistant to side loading

MODULAR CONSTRUCTION

- ◆ Service friendly
- ◆ Cost effective maintenance
- ◆ Simple and durable rotator

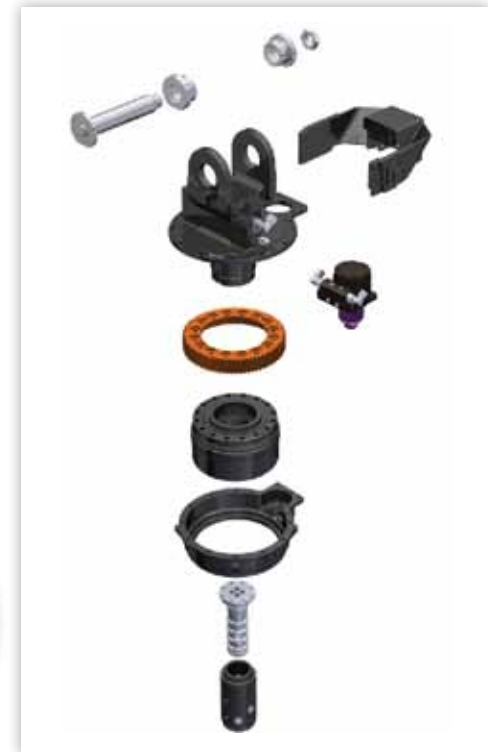

Expressions Grafik • Printed in Canada • V.20110829_metric measurements

ROTOBEC INC.

HEAD OFFICE

Tel: 418 383.3002

Fax: 418 383.5334

rotobec@rotobec.com



ROTOBEC™

www.rotobec.com